



TECHNICAL DATA SHEET

Mod. AF 50.35



GENERAL FEATURES

- Rack size **50x50 cm**
- Gross weight: 61 Kg
- Washing cycles / racks/hour : 90"-120"/ 40-30
- Top and bottom wash/rinse arms
- Wash pump 550 W
- Boiler capacity 5 liters
- Tank capacity 20 liters
- Boiler heating element 4,5 kW
- Tank heating element 2.4 kW
- Water quantity per cycle 2 liters
- Electromechanical controls
- Extractable control panel
- Useful washing height:350 mm
- Magnetic door microswitch
- Automatic water filling
- Built-in rinse aid dispenser (adjustable)
- Hot rinse
- Thermostop function
- Anti back-flow valve

FILTRATION

- Plastic wash pump filter, easily removable

BODY

- AISI 304 stainless steel Body
- Partial double skinned body
- Preformed rack guides
- Preformed wash tank
- Double skinned door
- Door handle in s/s
- Wash/rinse arms in s/s, easily removable
- Boiler in s/s AISI 304
- PVC protection rear the bottom front panel

EQUIPMENT

- 1 glass rack 50x50 cm
- 1 plates rack 50x50 cm (12/18 plates)
- 1 cutlery small basket
- 1 inlet hose (length 2 mt)
- 1 drain hose (length 2,5 mt)

OPTIONAL

- Electric detergent dispenser
- Electric rinse-aid dispenser
- Drain pump
- Rinse booster pump
- Cold rinse
- Kit s/s filters for pre-filtering of tank water
- Boiler heating element 6 kW
- Commutable voltage
- 60 Hz version

ACCESSORIES FOR THE WATER TREATMENT

- Internal water softener ("S" version)

ACCESSORIES

- Special racks
- S/S supporting stand h. mm. 545 for baskets

INSTALLATION

- Use the screws of the feet and a spirit level to ensure that the machine is levelled

MAIN POWER SUPPLY

- The voltage of main power supply must be compatible with the rated voltage
- The machine must be connected to a suitable earth (ground) system
- Connect the machine power socket to the multi-pole wall switch provided

WATER SUPPLY CONNECTION

- A water softener must be installed if the water is hard
- The water pressure must be between 0.2MPa (2 bar), and, 0.5MPa (5 bar)
- The temperature of the water-supply must be between 10°C to 50°C

TECHNICAL SPECIFICATIONS

- Voltage: **380-415V3N/220-240V3/220-240V~50Hz**
- Total power : **5,05 kW**
- Amperage: **8 A / 13 A / 22 A**
- Power cord supply size: **5x2.5 / 3x4 mmq**

AF 50.35

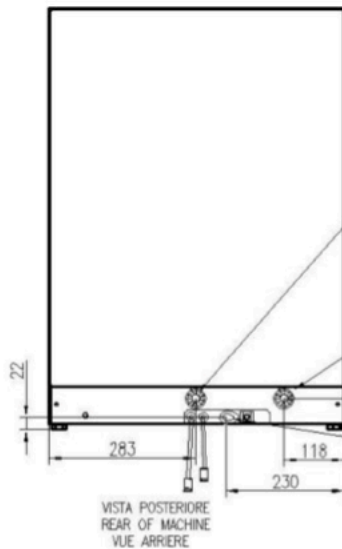
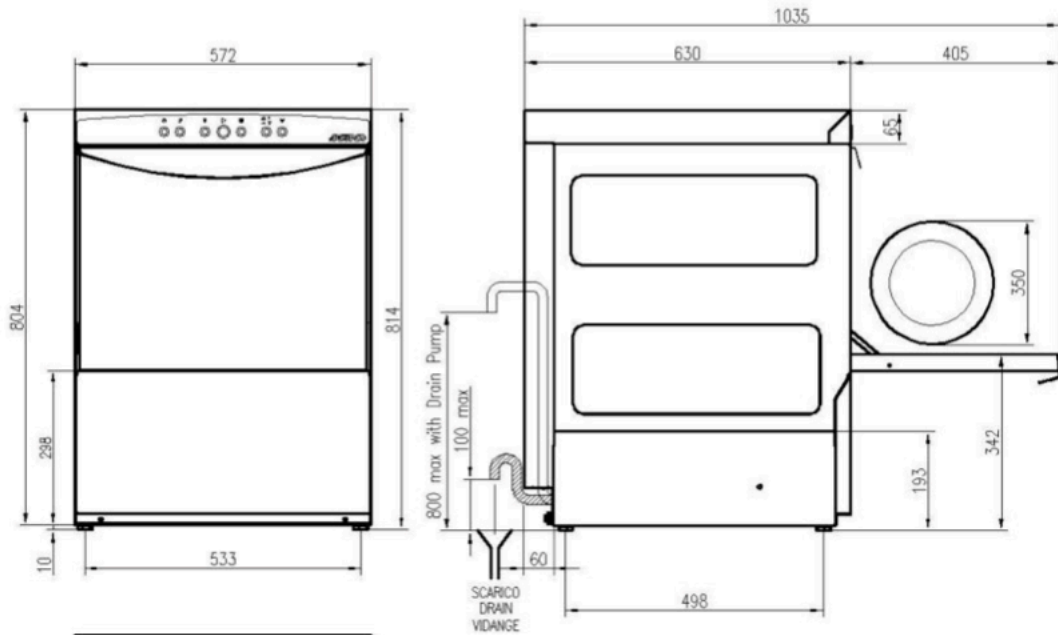

USCITA TUBO DI SCARICO ϕ INT. mm.20 L=mm.2500
 EXIT WATER OUTLET PIPE INT. ϕ 20 mm. L=mm.2500.
 OUVERTURE DE PASSAGE TUYAU DE VIDANGE ϕ INT. 20 mm. L=mm.2500.

CANNA DI CARICO CON ATTACCO G 3/4" L=mm. 2000.
 WATER INLET PIPE CONNECTION G 3/4" L=mm 2000.
 OUVERTURE DE PASSAGE TUYAU D'ALIMENTATION EAU AVEC
 CONNEXION G 3/4" L=mm 2000.

USCITA CAVO DI ALIMENTAZIONE
 EXIT POWER CORD SUPPLY
 OUVERTURE DE PASSAGE CABLE D'ALIMENTATION

VISTA POSTERIORE
 REAR OF MACHINE
 VUE ARRIERE

	Min 10°C-MAX 50°C
	Min 10°C-MAX 25°C with ENERGY RECOVERY
	200÷500kPa(2÷5 Bar)
	100÷500kPa(1÷5 Bar) with ATMOSPHERIC BOILER
	HARDNESS 5÷20f-2.8÷11'd